

刮板链  
Scraper Chain

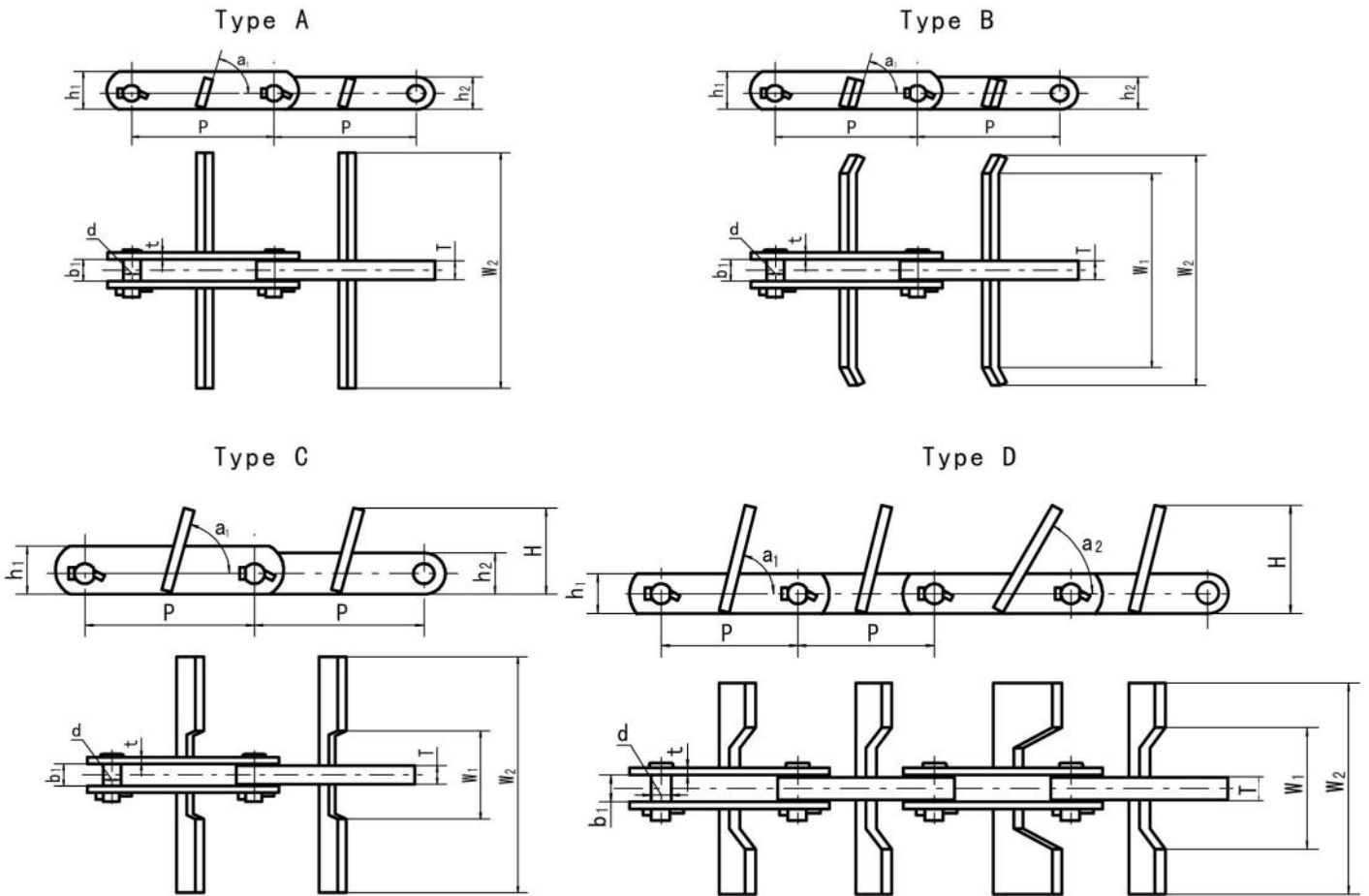

链号 Chain No.	节距 Pitch P mm	外节内宽 Width between sidebars b <sub>1</sub> (min) mm	销轴直径 Pin Diameter d mm	链板 Sidebar			刮板尺寸 Scraper dimensions					最小抗拉 强度 Ultimate tensile strength Q <sub>min</sub> kN	每米净重 Weight per meter q kg/m	型号 Type
				h <sub>1</sub> mm	h <sub>2</sub> mm	t/T mm	W <sub>1</sub> mm	W <sub>2</sub> mm	H mm	α <sub>1</sub> °	α <sub>2</sub> °			
HS150	150	26.4	18.5	44.5	38.1	8/22	-	280	-	90	-	315	11.9	A
HS150A	150	23.5	18.5	44.5	38.1	8/22	165	185	-	70	-	235.3	10.21	B
HS150B	150	23.5	18.5	44.5	38.1	8/22	165	185	-	90	-	235.3	9.554	A
SBS3101	101.6	23.5	18.5	44.5	38.1	8/22	60	135	80	90	-	235.3	12.14	C
HS150C	150	23.5	18.5	44.5	38.1	8/22	165	185	-	90	-	265	9.554	B
HS150E	150	23.5	18.5	44.5	38.1	8/22	265	285	-	90	-	235.3	10.55	B
HS150G	150	24	18.5	44.5	38.1	8/22	165	185	-	70	-	262.5	9.753	B
HS150H	150	24	18.5	44.5	38.1	8/22	-	220	-	70	-	262.5	12.53	A
SBS3152-236	152.4	30	22.12	44.5	-	8/25	136	236	120	75	60	262.5	21.66	D